

UNIVERSAL TRADE LIFT



The UTL, designed to maximise flexibility, accommodates your lifting requirements regardless of vehicle model or bin size.



THE WHEELS ARE ALWAYS TURNING



UNIVERSAL TRADE LIFT

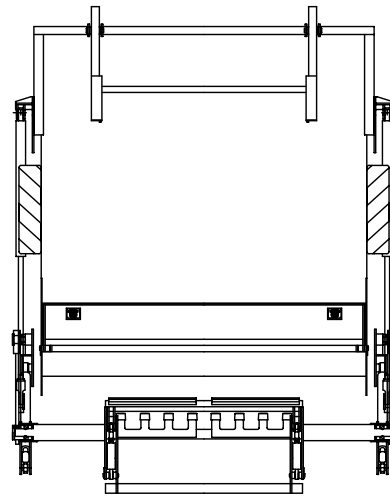
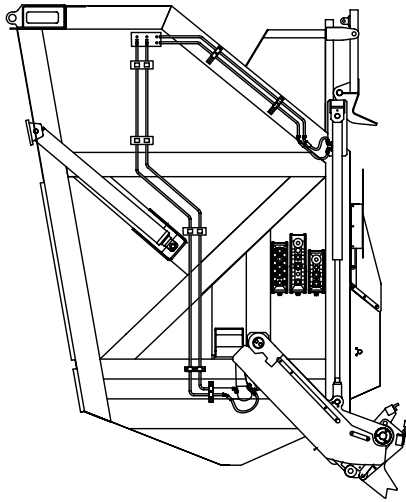

FEATURES & BENEFITS

Feature	Benefit
Designed for maximum flexibility.	Lifts and empties containers generally complying with EN840, sections 1-3, ranging from 120 litres to 1280 litres, with 2 and 4 wheels or without roll-top lids, together with the traditional round paladin squeeze clamp 36" bins.
New design action - container is lifted vertically with little rotation until it reaches the top where it is then rotated, dumping the refuse into the hopper.	Does not kick bins away and will accommodate virtually any bin location. Compact space efficient design
Simple interlocks on the automatic clamping of comb lift bins.	Risk of emptying unclamped containers is removed.
Paladin arms are an optional extra and containers are lifted through the use of 'girdle' type squeeze clamp arms that incorporate a soft action when parking.	Prevents potentially injury through operator entrapment
Automatic follow up clamp function during the hoist lift and empty sequence.	Reduced risk in the unlikely event of container slippage. Re-clamps slipping containers.
Retractable air-cushioned lid openers fitted together with gas strut-controlled drop down rave.	Smooth, damped movements extended service life.
Rave designed to be pushed back when the hopper is over full.	Eliminates damage to rave extension or hoist.
Rave can be lowered by hand.	Allows hand loading.
When rave is lowered the packer reverts automatically to 'hold to run' and the hoist cannot be operated.	Ensures safety of operator and equipment.
In normal operation with rave door raised the packer is in auto-cycle and will receive a start signal when the hoist is operated.	Increases hopper capacity and reduces spillage. Speed of automatic
Hoist cycle time is 18 seconds.	Information only
Auto clamp of containers with safety interlocks.	Hoist will not empty an unclamped container.
Minimal opening with soft park on Paladin arms.	Promotes confidence with safe operation.
PLC control to IP65.	Sealed against water ingress.
Proximity switch control with LED identification.	No moving parts. Simple fault finding.
Dual push button operation.	Ease of operation when handling bins.
Greased moving parts.	Planned service for longer life.
Independently selected air cushioned lid restraint.	Allows the operator full control over operation.

CONTROLS

Programmable logic control (PLC) for precision control. Electrical operated dual controls. All push buttons, relays and switches are protected to IP 65. Hoist incorporates beam controls with emergency stop buttons.

SAFETY FEATURES INCLUDE

Full CE certification. Minimal opening and soft park on paladin arms. Interlocks to ensure containers are clamped before emptying

OPTIONS:

Full range of options available.



HEIL EUROPE LIMITED

HILLEND INDUSTRIAL PARK, DUNFERMLINE KY11 9ES.

TELEPHONE: +44(0)1383 823 625 FAX: +44(0)1383 824 062

EMAIL: salesinfo@heil-europe.co.uk VISIT OUR WEB SITE: www.heileuro.com